

LECTURE NOTES 23

Eddy Currents in Conductors

Conductors, by definition, contain “free” electrons – i.e. the electrons are free to move around inside the metal, but in fact are (weakly) bound to the metal by the work function ϕ_W of the metal (SI units = eV (i.e. Joules)). Due to internal thermal energy associated with the metal being at finite temperature, the “free” electrons can “evaporate” from the metal via thermionic emission (from the high-side tail of the thermal energy distribution of the free electrons in a metal). Thus thermionic emission of electrons is intimately related to black body /thermal radiation.

Thermal energy distribution of “free” electrons in a metal:

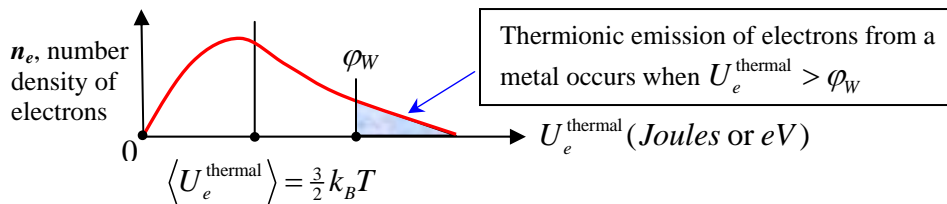

The free electrons in the metal have mean/average thermal kinetic energies of

$$\langle U_e^{\text{thermal}} \rangle = \frac{1}{2} m_e \langle v_e^2 \rangle = \frac{3}{2} k_B T$$

In the presence of a uniform applied external magnetic field $\vec{B}_{\text{ext}} = B_o \hat{z}$ the free electrons in metal move in circular orbits in a plane $\perp \vec{B}_{\text{ext}} = B_o \hat{z}$ (ignoring/neglecting scattering effects in the metal). The (mean/average) momentum of each electron is $\langle p_e \rangle = m_e \langle v_e \rangle = q B_o R$ where $R =$ (mean/average) radius of curvature of the circular orbit:

$$R = \frac{m_e \langle v_e \rangle}{q B_o} = \frac{m_e}{q B_o} \sqrt{\frac{3k_B T}{m_e}} = \frac{1}{q B_o} \sqrt{3m_e k_B T} \quad \text{and} \quad \langle v_e \rangle = \sqrt{\frac{3k_B T}{m_e}}$$

Note that $\langle v_e \rangle = \sqrt{\frac{3k_B T}{m_e}} \approx 1.2 \times 10^5 \text{ m/s}$ for $T = 300\text{K}$ (see P435 Lect. Notes 21, page 9), using:

$$m_e = 9.1 \times 10^{-31} \text{ kg}$$

$$q = 1.6 \times 10^{-19} \text{ Coulombs} = |e|$$

$$B_o = 1 \text{ Tesla}$$

$$k_B = 1.38 \times 10^{-23} \text{ J/K}$$

$$T = 300\text{K}$$

This corresponds to a radius of curvature of $R = 6.65 \times 10^{-7} \text{ m} = 0.665 \mu\text{m} \approx 0.7 \mu\text{m}$ for a $B_o = 1 \text{ Tesla}$ magnetic field!

This result (of course) assumes no scattering of the free electrons in the conducting metal while it is making one orbit of cyclotron motion:

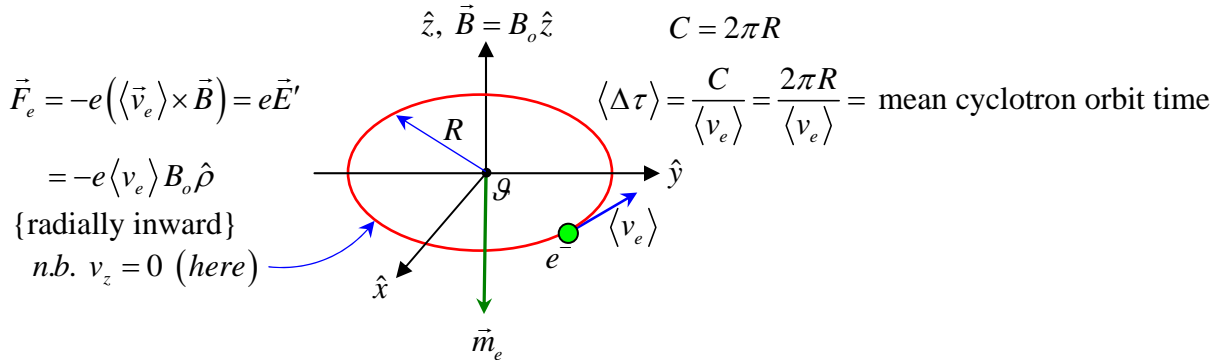

In general $v_z \neq 0$, thus free electrons will additionally move up/down \parallel to \hat{z} -axis in a helical/spiraling motion as shown in the figure below, since the electron's motion in z is unaffected by the presence of the externally-applied magnetic field:

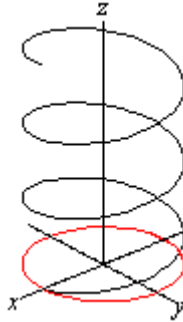

The magnetic dipole moment \vec{m}_e associated with a free electron in a cyclotron orbit is:

$$\vec{m}_e = I \vec{A}_{\perp} = I \overbrace{\pi R^2}^{-A_{\perp}} (-\hat{z}) = \left(\frac{e}{\langle \Delta \tau \rangle} \right) \pi R^2 (-\hat{z}) = \frac{e \langle v_e \rangle}{2\pi R} \cancel{\pi R^2} (-\hat{z}) = \frac{1}{2} e \langle v_e \rangle R (-\hat{z}) = -\frac{1}{2} e \langle v_e \rangle R \hat{z}$$

Note that induced/resulting magnetic dipole moment, $\vec{m}_e = -IA_{\perp} \hat{z} = -\frac{1}{2} e \langle v_e \rangle R \hat{z}$ points opposite direction of applied magnetic field.

\Rightarrow Free electrons in metal/conductor in the presence of B_{ext} have diamagnetic properties.

In reality the mean free path of a free electron in a metal, λ_{mfp} (= average/mean distance between scatterings/collision) in most metals is much smaller than $C = 2\pi R \approx 4.2 \mu\text{m}$ (for $T = 300\text{K}$ and $B_o = 1$ Tesla).

In copper metal for example:

$$\lambda_{mfp}^{Cu} = 3.9 \times 10^{-8} \text{ m} \approx 0.04 \mu\text{m} = 40 \text{ nm} / = 400 \text{ \AA} (!) \text{ Thus } \lambda_{mfp}^{Cu} \approx 0.04 \mu\text{m} \ll C = 2\pi R \approx 4.2 \mu\text{m},$$

i.e. $\lambda_{mfp}^{Cu} \approx \frac{1}{100} C$ in copper (for $T = 300\text{K}$ and $B_o = 1$ Tesla).

Where $\lambda_{mfp} = \frac{\sigma_c m_e \langle v_e \rangle}{n_e e^2}$. For copper $\sigma_c^{cu} \approx 5.95 \times 10^7$ Siemens and $n_e^{cu} \approx 8.5 \times 10^{28} / m^3$

$$\text{with } \langle v_e \rangle = \sqrt{\frac{3k_B T}{m_e}} \approx 1.2 \times 10^5 \text{ m/s for } T = 300K$$

In this regime the path of free electrons is more complex due to the intrinsic scattering processes extant in the metal, but the free electrons still travel (on average) in circular and/or helical paths.

Again, it is important to point out that static magnetic fields perform/carryout/ do NO work on charged particles. Thus, for a constant (i.e. time-independent) magnetic-field, e.g. $\vec{B} = B_o \hat{z}$, no net energy is deposited and/or removed from the metal conductor by the constant magnetic field.

All a constant magnetic field $\vec{B} = B_o \hat{z}$ does is change/rearrange the nature of the six-dimensional phase space associated with the free electrons $(\vec{r}_e, \vec{p}_e) = (x, y, z, p_x, p_y, p_z)$ by introducing correlations in $(x \ \& \ y)$, and $(p_x \ \& \ p_y)$ due to the induced cyclotron-type motion of the free electrons. The block of metal remains in thermal equilibrium.

In e.g. a sheet of copper metal, the free electron number density $n_e^{cu} \approx 8.5 \times 10^{28} / m^3$. If the copper metal sheet lies in the x - y plane, with $\vec{B}_{ext} = B_o \hat{z}$, then the net magnetic dipole moment is

$$\vec{m}_{net} = \sum_{i=1}^{N_e} \vec{m}_e = m_{net} (-\hat{z}) \text{ with macroscopic magnetization } \vec{M} = \vec{m}_{net} / \text{volume} = m_{net} (-\hat{z}) / \text{volume}$$

due to the free electrons only.

An effective surface \vec{K}_e current flows (only) on the periphery of the metal sheet – due to cancellation of the nearest neighbor induced dipole currents, as shown in the figure below:

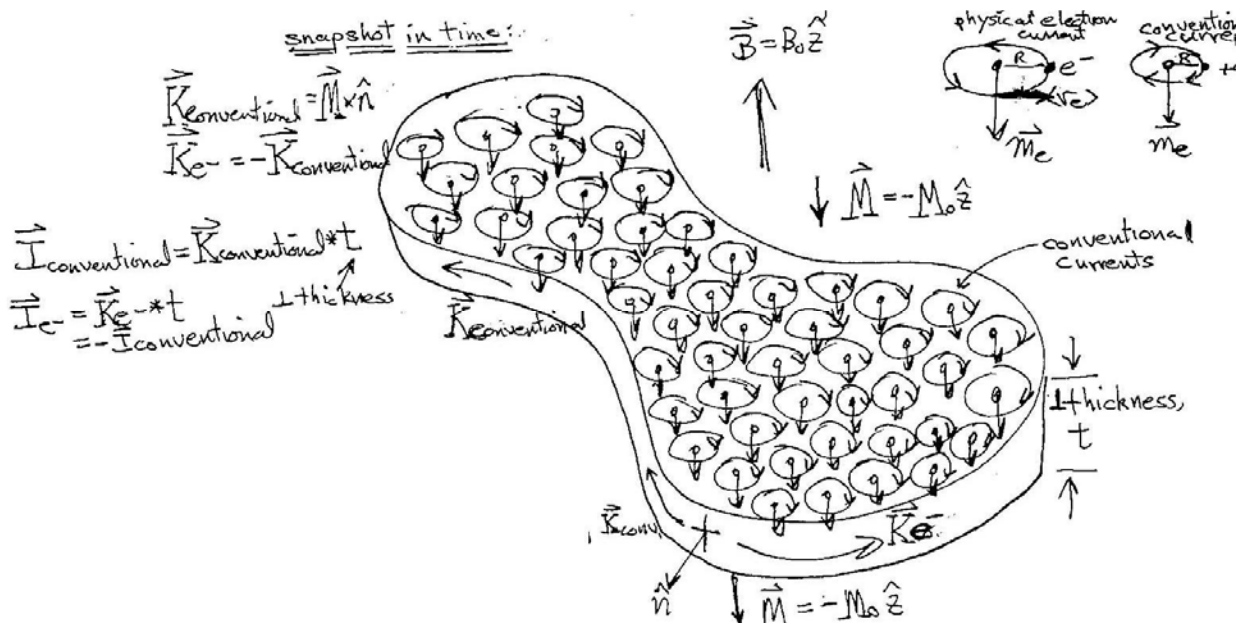

Again, there are NO power losses here with a static magnetic field because \vec{B} does NO work if $\vec{B} = \text{constant}$.

However for time-varying magnetic fields, because of Faraday's Law: $\vec{\nabla} \times \vec{E}(\vec{r}, t) = -\frac{\partial \vec{B}(\vec{r}, t)}{\partial t}$

$$\text{or: } \int_{S_{\perp}} \vec{\nabla} \times \vec{E}(\vec{r}, t) \cdot d\vec{a}_{\perp} = \oint_C \vec{E}(\vec{r}, t) \cdot d\vec{\ell} = -\int_{S_{\perp}} \frac{\partial \vec{B}(\vec{r}, t)}{\partial t} \cdot d\vec{a}_{\perp} = -\frac{\partial \Phi_m(t)}{\partial t} = \varepsilon mf \varepsilon(t)$$

a time-varying magnetic field $\frac{\partial \vec{B}(\vec{r}, t)}{\partial t}$ induces an electric field $\vec{E}(\vec{r}, t)$ which (depending on the sign of $\frac{\partial \vec{B}(\vec{r}, t)}{\partial t}$ (increasing/decreasing) either accelerates/decelerates the free electrons in the conducting metal.

\Rightarrow If $\vec{B}(t) = B_o(t) \hat{z}$ and $\frac{\partial \vec{B}(t)}{\partial t} = \frac{\partial B_o(t)}{\partial t} \hat{z}$ and for simplicity, if $\langle v_e \rangle$ is in the x - y plane,

i.e. $v_{e_z} = 0$ then the free electron's cyclotron orbit radius, R remains constant:

$$R = \frac{m_e \langle v_e \rangle}{eB} = \text{constant} \frac{m_e \frac{d(\langle v_e(t) \rangle)}{dt}}{e \frac{dB(t)}{dt}} \quad \text{or:} \quad \boxed{m_e \frac{d\langle v_e(t) \rangle}{dt} = e \frac{dB(t)}{dt}}$$

The (average) kinetic energy gain (or loss) per cyclotron orbit is:

$$\Delta KE_e(t) = q * (\varepsilon mf \varepsilon_e(t)) = -e * (\varepsilon mf \varepsilon_e(t)) = +e \frac{\partial \Phi_m(t)}{\partial t} = e \frac{\partial B(t)}{\partial t} A_{\perp} \quad \text{where } A_{\perp} = \pi R^2$$

The (average) rate of a free electron's kinetic energy gain (or loss) per cyclotron orbit is thus:

$$\text{The power gain/loss per cyclotron orbit: } P(t)_e = \frac{\Delta KE_e(t)}{\tau_{rev}} = \frac{e \frac{\partial B(t)}{\partial t} * (\pi R^2)}{\tau_{rev}}$$

$$\text{but: } \tau_{rev} \approx \frac{C}{\langle v_e \rangle} = \frac{2\pi R}{\langle v_e \rangle}$$

$$\text{Thus: } P_e(t) = \frac{e \frac{\partial B(t)}{\partial t} * (\cancel{\pi} R^{\cancel{2}})}{2\cancel{\pi} R} \langle v_e \rangle = \frac{1}{2} e \langle v_e \rangle R \frac{\partial B(t)}{\partial t} \quad \text{But: } \boxed{\vec{m}_e = -\frac{1}{2} e \langle v_e \rangle R \hat{z}} \quad (\text{from above})$$

$$\text{Therefore: } P_e(t) = \frac{1}{2} e \langle v_e \rangle R \frac{\partial B(t)}{\partial t} = -\vec{m}_e \cdot \frac{\partial \vec{B}(t)}{\partial t} = \frac{\partial [-\vec{m}_e \cdot \vec{B}(t)]}{\partial t} = \frac{\partial U_e^{mag}(t)}{\partial t}$$

Note: By Lenz's Law, P_e is always positive for diamagnetic conducting materials. Then the macroscopic power: $P_{macro}(t) = N_e P_e(t) = n_e * \text{volume} * P_e(t)$ corresponds to the macroscopic induced EMF ε_{macro} and (net) macroscopic current, I_{macro} flowing in the conducting material!!!

Then we see that
$$P_{macro}(t) = \varepsilon_{macro}(t) I_{macro}(t) = I_{macro}^2(t) R_{material} = \varepsilon_{macro}^2(t) / R_{material}$$

 = Joule heating / power losses in the metal.

The (net) macroscopic current $\vec{I}_{macro}(t)$ flows around periphery of material, as a surface current $\vec{K}_{macro}(t)$, then $\vec{I}_{macro}(t) = \vec{K}_{macro}(t) t_{\perp}$, where t_{\perp} = perpendicular thickness of the conducting material (see above figure).

Note that *this* surface current $\vec{K}_{macro}(t)$, which is created by an externally-created $\partial B(t)/\partial t$ in the metal is associated with real power losses/real power dissipation because of the acceleration/deceleration of free electrons in the metal (which *is* a time-irreversible process).

Such induced macroscopic currents in conductors/metals, caused by an induced macroscopic

EMF
$$\varepsilon_{macro}(t) = -\frac{d\Phi_m(t)}{dt} = -\frac{\partial B(t)}{\partial t} A_{\perp}^{macro}$$
 are known as Eddy currents.

Eddy currents e.g. in transformers are harmful because they sap power from the transformer:

power input = (power output + Eddy current power)
thus: power output = (power input - Eddy current power)

Since Eddy current power winds up as heat, the transformer will (eventually) get hot – possibly so hot it could be destroyed, if it has not been designed properly!

Eddy currents in metals can also be used beneficially e.g. to cook food by induction heating!!
 ⇒ Place food in metal container in proximity to intense alternating \vec{B} -field. Eddy current power losses (e.g. in transformers) can be dramatically reduced by laminating the transformer core.

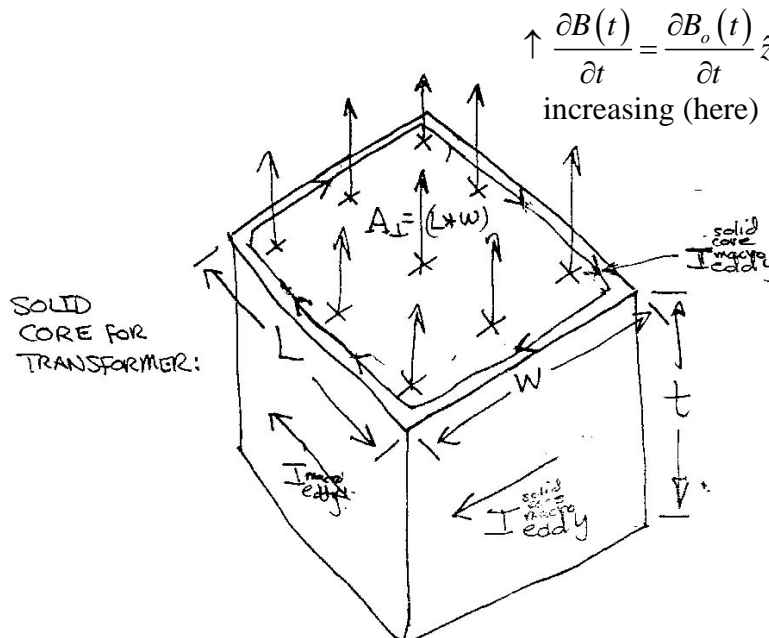

For a Solid-Core Transformer:

The induced macroscopic $\epsilon_{macro\ Eddy}^{solid\ core} (t) = -\frac{\partial \Phi_m(t)}{\partial t} = -\frac{\partial \vec{B}(t)}{\partial t} A_{\perp}^{solid\ core}$ where $A_{\perp}^{solid\ core} = (L * W)$

The power dissipation in the solid core of this transformer is:

$$P_{macro\ Eddy}^{solid\ core} (t) = \epsilon_{macro\ Eddy}^{solid\ core} (t) I_{macro\ Eddy}^{solid\ core} (t) = I_{macro\ Eddy}^{solid\ core} (t) R_{solid\ core} = \frac{\epsilon_{macro\ Eddy}^{solid\ core} (t) \left(\frac{\partial B(t)}{\partial t}\right)^2 A_{\perp}^{2\ core}}{R_{solid\ core}}$$

$$P_{macro\ Eddy}^{solid\ core} (t) = \frac{\left(\frac{\partial B(t)}{\partial t}\right)^2 A_{\perp}^{2\ core}}{R_{solid\ core}} = \frac{\left(\frac{\partial B(t)}{\partial t}\right)^2 L^4}{R_{solid\ core}} \text{ if } A_{\perp}^{solid\ core} = L^2 \text{ (i.e. } L = W \text{ for a square core)}$$

For a Laminated Core Transformer:

Divide the solid core into N_{lam} individual laminations, each of width ΔW . Coat each lamination with a very thin layer of electrically-insulating material (e.g. varnish or epoxy). Then the total width of all laminations stacked back together is $W = N_{lam} \Delta W$.

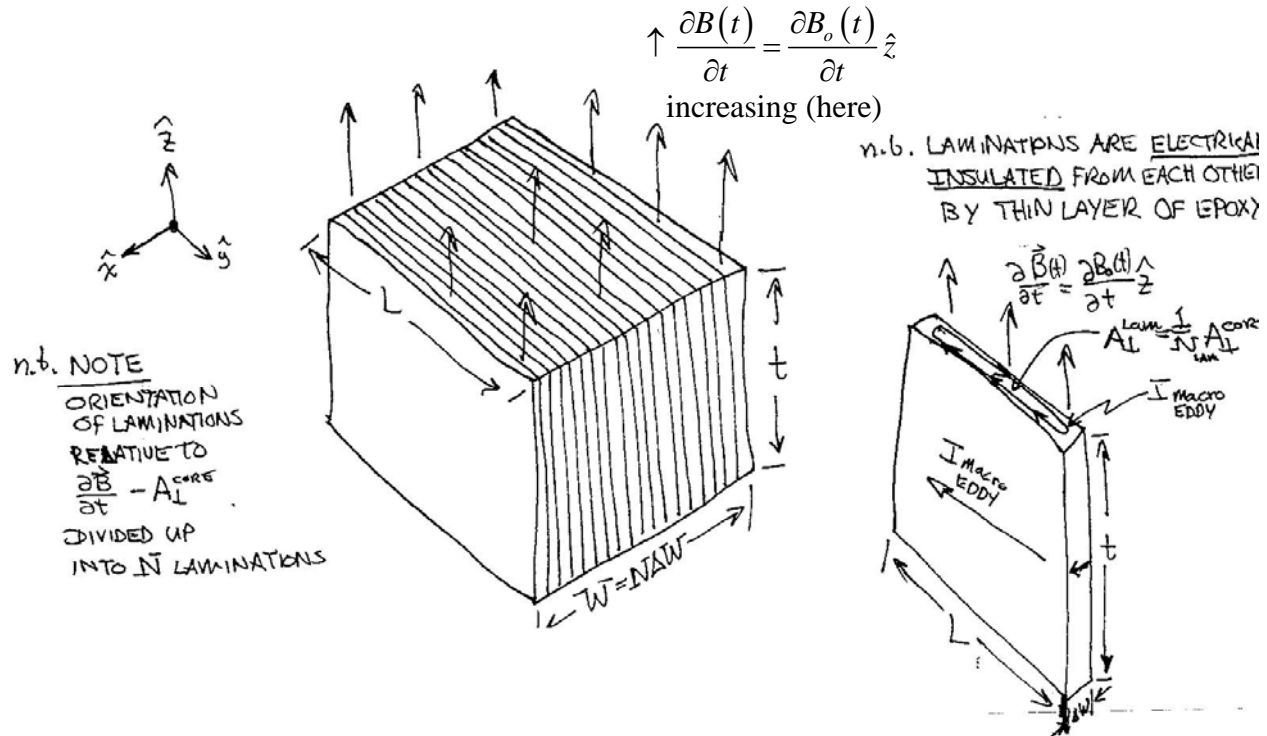

Each (now insulated) lamination has a cross-sectional area $A_{\perp}^{Lam} = L \Delta W = \frac{1}{N_{Lam}} A_{\perp}^{core}$

The resistance of each lamination is now increased relative to the resistance of the whole core:
 $R_{Lam} = N_{Lam} R_{core}$ (i.e. $R_{core} = R_{Lam} / N_{Lam}$ - for N_{Lam} laminations electrically connected in parallel).

The induced macroscopic EMF associated with each lamination is:

$$\varepsilon_{\text{Eddy}}^{\text{Lam}}(t) = -\frac{\partial \Phi_m(t)}{\partial t} = -\frac{\partial \vec{B}(t)}{\partial t} \cdot \vec{A}_{\perp}^{\text{Lam}} \quad \text{where} \quad A_{\perp}^{\text{Lam}} = L * \Delta W = L * (W / N_{\text{Lam}}) = A_{\perp}^{\text{solid core}} / N_{\text{Lam}}$$

The corresponding Eddy current power loss associated with each lamination is:

$$P_{\text{Lam}}(t) = \frac{\varepsilon_{\text{Eddy}}^{\text{Lam}}(t)^2}{R_{\text{Lam}}} = \frac{\left(\frac{\partial B(t)}{\partial t}\right)^2 A_{\perp}^{\text{Lam}2}}{R_{\text{Lam}}} = \frac{\left(\frac{\partial B(t)}{\partial t}\right)^2 A_{\perp}^{\text{solid core}2} / N_{\text{Lam}}^2}{N_{\text{Lam}} R_{\text{solid core}}} = \frac{1}{N_{\text{Lam}}^3} \frac{\left(\frac{\partial B(t)}{\partial t}\right)^2 A_{\perp}^{\text{solid core}2}}{R_{\text{solid core}}} = \frac{1}{N_{\text{Lam}}^3} P_{\text{solid core}}(t)$$

Since there are N_{lam} laminations (now) making up the transformer core, then the total Eddy current power loss of the laminated transformer core is N_{lam} times the power loss for one lamination, i.e.:

$$P_{\text{Lam core}}^{\text{Tot}}(t) = N_{\text{Lam}} P_{\text{Lam}}(t) = \frac{1}{N_{\text{Lam}}^2} \frac{\left(\frac{\partial B(t)}{\partial t}\right)^2 A_{\perp}^{\text{solid core}2}}{R_{\text{solid core}}} = \frac{1}{N_{\text{Lam}}^2} P_{\text{solid core}}$$

Thus, we see that the Eddy current power loss in a transformer decreases as the square of the number of laminations (compared to no laminations) (i.e. the Eddy current power loss decreases as the square of A_{\perp}^{Lam})

n.b. Ferrite cores used in transformers have high resistance (e.g. compared to iron cores) and also have good magnetic permeability \Rightarrow the use of ferrite materials in transformer cores can reduce Eddy current losses even further, by a factor of $R_{\text{iron}} / R_{\text{ferrite}} \ll 1$!!! The use of ferrite materials for transformer cores is most common/most useful for low-power/small-signal applications.

Today, there exist various kinds of magnetic field sensors – e.g. which utilize magneto-resistive effects (B -field dependent resistance!) such as Giant Magneto-Resistance (GMR) sensors, and/or electron Spin-Dependent Tunnelling (SDT) devices as well as Superconducting Quantum Interference Devices (SQUIDS) which are also very sensitive to magnetic fields. These devices are used in all kind of applications to detect small variations in magnetic fields.

One important application is Eddy current sensing – used for detecting structural flaws in critical conducting materials. The state-of-the-art of Eddy current sensing is now such that imaging capability with ~ 100 micron resolution has been achieved. Please see/read handout on Eddy current sensing for more information.

Energy Stored in Magnetic Fields

In electrical circuits containing (one or more) inductors, work must be done against the back

$$\text{emf } \mathcal{E}_L(t) = -\frac{\partial \Phi_m(t)}{\partial t} = -L \frac{\partial I_{\text{free}}(t)}{\partial t} \text{ in order to get a free current, } I_{\text{free}} \text{ to flow in the circuit.}$$

Suppose we have a simple electrical circuit consisting of a battery (which supplies a constant emf, \mathcal{E}_o), an on/off switch, an inductor, (with inductance, L) and a resistor (of resistance, R) as show in the figure below:

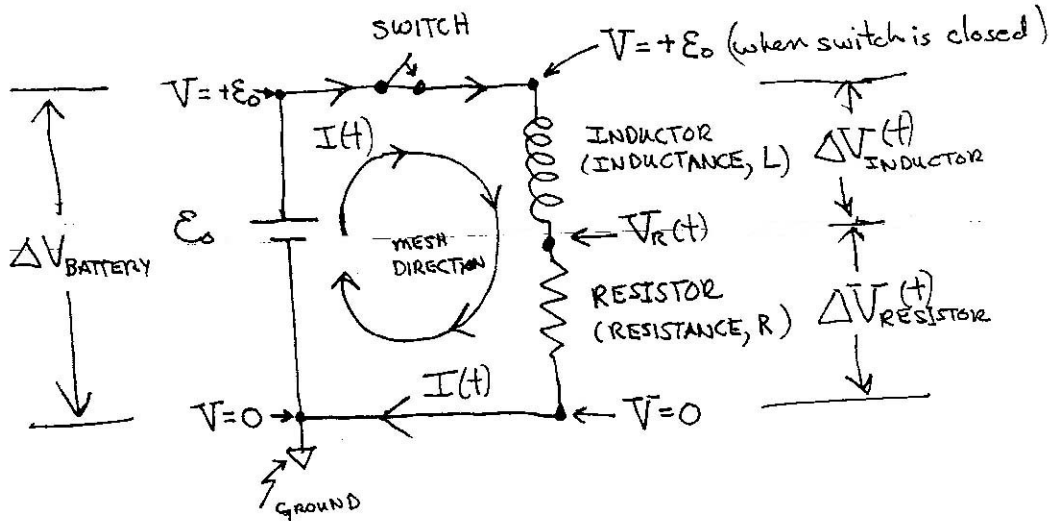

Then: $\Delta V_{\text{Tot}} = \oint_C \vec{E} \cdot d\vec{l} = 0 \leftarrow$ Kirchoff's Voltage Law: The sum of potential differences around a closed circuit (mesh) = 0, i.e. $\sum_{i=1}^N \Delta V_i = 0$.

$\Rightarrow \vec{E}$ is a conservative field associated with a conservative force $\vec{F} = q\vec{E}$

Then: $\Delta V_{\text{battery}} + \Delta V_{\text{inductor}}(t) + \Delta V_{\text{resistor}}(t) = 0$

Where: $\Delta V_{\text{battery}} = (\mathcal{E}_o - 0) = \text{constant}, \neq \text{fcn}(t)$

$$\Delta V_{\text{inductor}}(t) = (V_R(t) - \mathcal{E}_o)$$

$$\Delta V_{\text{resistor}}(t) = (0 - V_R(t))$$

Then: $\Delta V_{\text{battery}} + \Delta V_{\text{inductor}}(t) + \Delta V_{\text{resistor}}(t) = 0$
 $= (\mathcal{E}_o - 0) + (V_R(t) - \mathcal{E}_o) + (0 - V_R(t)) = 0$

or:
$$\mathcal{E}_o = -\underbrace{(V_R(t) - \mathcal{E}_o)}_{\substack{= \Delta V_{\text{inductor}}(t) \\ = -\mathcal{E}_L(t) \text{ (Back emf)}}} + \underbrace{V_R(t)}_{\substack{= \Delta V_{\text{resistor}}(t) \\ = I_{\text{free}}(t)R \\ \text{(by Ohm's Law)}}$$

$$\therefore \boxed{\mathcal{E}_0 = -\mathcal{E}_L(t) + I_{free}(t)R} = \text{constant, but } \boxed{\mathcal{E}_L(t) = -L \frac{\partial I_{free}(t)}{\partial t}}$$

$$\therefore \boxed{\mathcal{E}_0 = +L \frac{\partial I_{free}(t)}{\partial t} + I_{free}(t)R}$$

or: $\boxed{L \frac{\partial I_{free}(t)}{\partial t} + R I_{free}(t) = \mathcal{E}_0}$ \leftarrow 1st order linear inhomogeneous differential equation (solution is = general solution of homogeneous differential equation + particular solution for inhomogeneous equation (imposed by initial conditions and/or final conditions))

First, solve the homogeneous differential equation:

$$\boxed{L \frac{\partial I_{free}(t)}{\partial t} + R I_{free}(t) = 0} \Rightarrow \boxed{\left(\frac{L}{R}\right) \frac{dI_{free}(t)}{dt} + I_{free}(t) = 0} \text{ or: } \boxed{\frac{dI_{free}(t)}{dt} = -\left(\frac{R}{L}\right) I_{free}(t)}$$

The general solution to this homogeneous differential equation is of the form:

$$\boxed{I_{free}(t) = I_o^{free} e^{-t/\tau} + C} \text{ where } C = \text{constant of integration.}$$

Then: $\boxed{\frac{dI_{free}(t)}{dt} = -\frac{1}{\tau} I_o^{free} e^{-t/\tau}} \Rightarrow \boxed{\tau \equiv \left(\frac{L}{R}\right)}$ = characteristic time constant (SI units = seconds)

Now solve the inhomogeneous differential equation:

$$\boxed{L \frac{\partial I_{free}(t)}{\partial t} + R I_{free}(t) = \mathcal{E}_0} \text{ but } \boxed{I_{free}(t) = I_o^{free} e^{-t/\tau} + C}$$

Thus: $-\left(\frac{L}{R}\right) \left(\frac{R}{L}\right) I_o e^{-t/\tau} + I_o e^{-t/\tau} + C = \frac{\mathcal{E}_0}{R} \Rightarrow$ integration constant $\boxed{C = \frac{\mathcal{E}_0}{R}}$

\therefore The solution of this inhomogeneous differential equation is: $\boxed{I_{free}(t) = I_o^{free} e^{-t/\tau} + \frac{\mathcal{E}_0}{R}}$

However we don't (yet) know explicitly what I_o^{free} is...

\therefore Impose the initial condition at time $t = 0$: $\boxed{I_{free}(t=0) = 0}$.

i.e. initially no current flows through the circuit when the switch is closed at $t = 0$
(this is due to the back EMF in the inductor – i.e. Lenz's law!!!)

Thus at $t = 0$, we see that $\boxed{I_{free}(t=0) = I_o^{free} \underbrace{e^{-0}}_{=1} + \frac{\mathcal{E}_0}{R} = I_o^{free} + \frac{\mathcal{E}_0}{R} = 0} \Rightarrow \boxed{I_o^{free} = -\frac{\mathcal{E}_0}{R}}$

\therefore The specific solution to the inhomogeneous differential equation (here) is:

$$\boxed{I_{free}(t) = -\frac{\mathcal{E}_0}{R} e^{-t/\tau} + \frac{\mathcal{E}_0}{R} = \frac{\mathcal{E}_0}{R} \left(1 - e^{-t/\tau}\right)}$$

Thus, for this circuit, the free current flowing in this circuit as a function of time is:

$$I_{free}(t) = \left(\frac{\epsilon_0}{R}\right) \left(1 - e^{-t/\tau}\right) \quad \text{where} \quad \tau \equiv \left(\frac{L}{R}\right)$$

The free current $I_{free}(t)$ flowing in circuit vs. time, t is shown in the figure below:

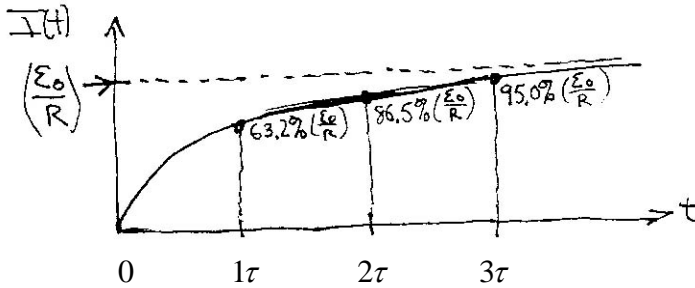

n.b. this electrical current flows through all components (i.e. battery, inductor, resistor, switch, wires...)

The voltage (aka potential difference) across the resistor, R vs. time, t :

$$\Delta V_R(t) = I(t) * R \text{ (by Ohm's Law)} = \frac{\epsilon_0}{R} * R \left(1 - e^{-t/\tau}\right)$$

$$\Delta V_R(t) = \epsilon_0 \left(1 - e^{-t/\tau}\right) \quad \text{where} \quad \tau \equiv \left(\frac{L}{R}\right)$$

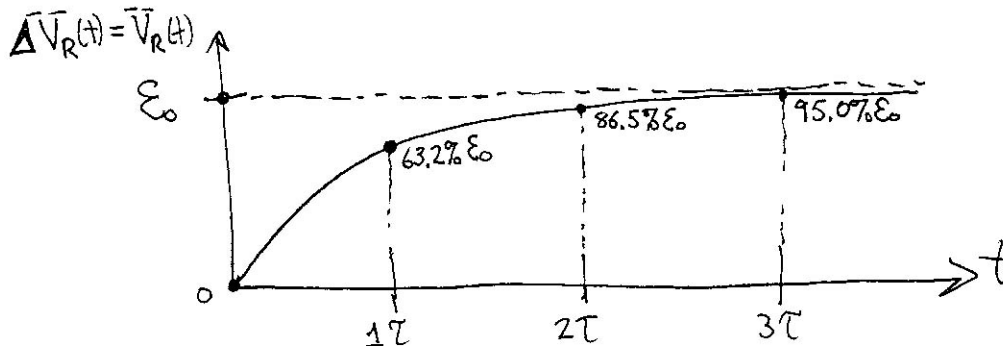

The voltage (aka potential difference) across the inductor, L vs. time, t :

Since: $I_{free}(t) = \left(\frac{\epsilon_0}{R}\right) \left(1 - e^{-t/\tau}\right)$ where $\tau \equiv \left(\frac{L}{R}\right)$ Thus:

$$\Delta V_{inductor}(t) = -\epsilon_L(t) = +L \frac{\partial I_{free}(t)}{\partial t} = L \left(-\left(\frac{\epsilon_0}{R}\right) \left(\frac{R}{L}\right) e^{-t/\tau} \right) = -\epsilon_0 e^{-t/\tau} \quad \text{i.e.} \quad \Delta V_{inductor}(t) = -\epsilon_0 e^{-t/\tau}$$

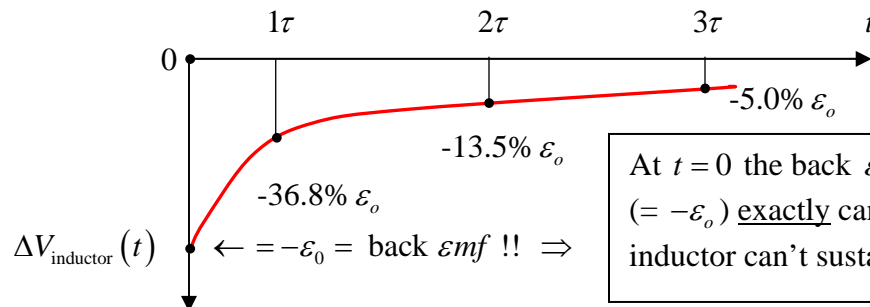

Kirchoff's Voltage Law: $\Delta V_{\text{battery}}(t) = -\Delta V_{\text{inductor}}(t) - \Delta V_{\text{resistor}}(t)$ (Volts)

$$\varepsilon_o = +\varepsilon_o e^{-t/\tau} + \varepsilon_o (1 - e^{-t/\tau}) = \varepsilon_o \text{ (Volts)}$$

The voltage (potential difference) across the battery = voltage (potential difference) across [inductor & resistor] = constant, independent of time.

The instantaneous electrical *power* stored in the inductor is:

$$P_L(t) = -\varepsilon_L(t) I_{\text{free}}(t) = +LI_{\text{free}}(t) \frac{dI_{\text{free}}(t)}{dt} \text{ (Watts)}$$

The instantaneous electrical *energy* stored in the inductor is:

$$W_L(t) = \int_0^t P(t') dt' = \int_0^t LI_{\text{free}}(t) \frac{dI_{\text{free}}(t')}{dt'} dt' = L \int_0^t I_{\text{free}}(t') dI_{\text{free}}(t') = \frac{1}{2} LI_{\text{free}}^2(t)$$

$$W_L(t) = \frac{1}{2} LI_{\text{free}}^2(t) \text{ (Joules) \{n.b. analog of } W_C(t) = \frac{1}{2} C\Delta V^2(t) \text{ for capacitors!\}}$$

Thus, we see that the instantaneous electrical power stored in the inductor is:

$$P_L(t) = \frac{dW_L(t)}{dt} = -\varepsilon_L(t) I_{\text{free}}(t) = +LI_{\text{free}}(t) \frac{dI_{\text{free}}(t)}{dt} \text{ (Watts)}$$

Recall that the magnetic flux in an inductor is: $\Phi_m(t) = LI_{\text{free}}(t)$ (Webers or Tesla-m²)

However: $\Phi_m(t) = \int_{S_{\perp}} \vec{B}(\vec{r}, t) \cdot d\vec{a}_{\perp} = \int_{S_{\perp}} (\vec{\nabla} \times \vec{A}(\vec{r}, t)) \cdot d\vec{a}_{\perp} = \oint_C \vec{A}(\vec{r}, t) \cdot d\vec{\ell} = LI_{\text{free}}(t)$

Then:
$$W_L(t) = \frac{1}{2} LI_{\text{free}}^2(t) = \frac{1}{2} [LI_{\text{free}}(t)] I_{\text{free}}(t) = \frac{1}{2} \left[\oint_C \vec{A}(\vec{r}, t) \cdot d\vec{\ell} \right] I_{\text{free}}(t)$$

$$= \frac{1}{2} I_{\text{free}}(t) \left[\oint_C \vec{A}(\vec{r}, t) \cdot d\vec{\ell} \right] = \frac{1}{2} \oint_C \vec{A}(\vec{r}, t) \cdot (I_{\text{free}}(t) d\vec{\ell}) = \frac{1}{2} \oint_C (\vec{A}(\vec{r}, t) \cdot \vec{I}_{\text{free}}(t)) d\ell$$

Thus, more generally, for any magnetic vector potential, $\vec{A}(\vec{r}, t)$ with its corresponding filamentary/line free current $\vec{I}_{\text{free}}(t)$, or surface free current density $\vec{K}_{\text{free}}(t)$, or volume free current density $\vec{J}_{\text{free}}(t)$ we see that the magnetic energy stored in such systems can be written as:

$$W_{\text{mag}}(t) = \frac{1}{2} \oint_C (\vec{A}(\vec{r}, t) \cdot \vec{I}_{\text{free}}(\vec{r}, t)) d\ell = \frac{1}{2} I_{\text{free}}(t) \oint_C \vec{A}(\vec{r}, t) \cdot d\vec{\ell} \text{ (Joules)}$$

$$W_{\text{mag}}(t) = \frac{1}{2} \int_{S_{\perp}} (\vec{A}(\vec{r}, t) \cdot \vec{K}_{\text{free}}(\vec{r}, t)) da_{\perp} \text{ (Joules)}$$

$$W_{\text{mag}}(t) = \frac{1}{2} \int_v (\vec{A}(\vec{r}, t) \cdot \vec{J}_{\text{free}}(\vec{r}, t)) d\tau \text{ (Joules)}$$

Note from the last formula above that the energy density associated with an inductor is:

$$u_{\text{mag}}(t) = \frac{1}{2} \vec{A}(\vec{r}, t) \cdot \vec{J}_{\text{free}}(\vec{r}, t) \text{ (Joules/m}^3\text{)}$$

Using Ampere's law (in differential form): $\vec{\nabla} \times \vec{B}(\vec{r}, t) = \mu_o \vec{J}_{Tot}(\vec{r}, t)$, then for non-magnetic media we see that $\vec{J}_{Tot}(\vec{r}, t) = \vec{J}_{free}(\vec{r}, t)$ (only) whereas for magnetic media, in general $\vec{J}_{Tot}(\vec{r}, t) = \vec{J}_{free}(\vec{r}, t) + \vec{J}_{Bound}(\vec{r}, t)$.

Then we can more generally write $W_{mag}(t) = \frac{1}{2} \int_v (\vec{A}(\vec{r}, t) \cdot \vec{J}_{free}(\vec{r}, t)) d\tau$ as

$$W_{mag}(t) = \frac{1}{2} \int_v (\vec{A}(\vec{r}, t) \cdot \vec{J}_{Tot}(\vec{r}, t)) d\tau = \frac{1}{2\mu_o} \int_v (\vec{A}(\vec{r}, t) \cdot \vec{\nabla} \times \vec{B}(\vec{r}, t)) d\tau$$

Integrate the RHS term of the above relation by parts, and use the relation:

$$\vec{\nabla} \cdot (\vec{A} \times \vec{B}) = \vec{B} \cdot (\vec{\nabla} \times \vec{A}) - \vec{A} \cdot (\vec{\nabla} \times \vec{B})$$

$$\text{i.e. } \vec{A} \cdot (\vec{\nabla} \times \vec{B}) = \vec{B} \cdot (\vec{\nabla} \times \vec{A}) - \vec{\nabla} \cdot (\vec{A} \times \vec{B}) = \vec{B} \cdot \vec{B} - \vec{\nabla} \cdot (\vec{A} \times \vec{B}) = B^2 - \vec{\nabla} \cdot (\vec{A} \times \vec{B})$$

$$\therefore W_{mag}(t) = \frac{1}{2\mu_o} \left[\int_v B^2(\vec{r}, t) d\tau - \int_v \vec{\nabla} \cdot (\vec{A}(\vec{r}, t) \times \vec{B}(\vec{r}, t)) d\tau \right]$$

Using the divergence theorem on the 2nd term:

$$W_{mag}(t) = \frac{1}{2\mu_o} \left[\int_v B^2(\vec{r}, t) d\tau - \oint_S (\vec{A}(\vec{r}, t) \times \vec{B}(\vec{r}, t)) \cdot d\vec{a} \right] \text{ (n.b. surface } S \text{ encloses volume } v)$$

The volume of integration v = entire volume occupied by the current density $\vec{J}_{Tot}(\vec{r}, t)$. Any integration volume larger than this is perfectly fine also, so integrating over all space for a localized/finite volume current distribution $\vec{J}_{Tot}(\vec{r}, t)$ is also fine. Then for an infinite integration volume v with accompanying infinite enclosing surface S , we see that the surface integral on the RHS of the above equation vanishes, i.e. $\oint_{S_\infty} (\vec{A}(\vec{r}, t) \times \vec{B}(\vec{r}, t)) \cdot d\vec{a} = 0$.

Then the magnetic energy associated with any system is given by:

$$W_{mag}(t) = \int_{space}^{all} u_{mag}(\vec{r}, t) d\tau = \frac{1}{2} \int_{space}^{all} (\vec{A}(\vec{r}, t) \cdot \vec{J}_{Tot}(\vec{r}, t)) d\tau \text{ (Joules) or equivalently by:}$$

$$\begin{aligned} W_{mag}(t) &= \int_{space}^{all} u_{mag}(\vec{r}, t) d\tau = \frac{1}{2\mu_o} \int_{space}^{all} B^2(\vec{r}, t) d\tau \\ &= \frac{1}{2\mu_o} \int_{space}^{all} (\vec{B}(\vec{r}, t) \cdot \vec{B}(\vec{r}, t)) d\tau = \frac{1}{2} \int_{space}^{all} (\vec{B}(\vec{r}, t) \cdot \vec{H}(\vec{r}, t)) d\tau \end{aligned} \text{ (Joules)}$$

The corresponding magnetic energy density is given by:

$$u_{mag}(\vec{r}, t) = \frac{1}{2} \vec{A}(\vec{r}, t) \cdot \vec{J}_{Tot}(\vec{r}, t) \text{ (Joules/m}^3\text{) or equivalently by:}$$

$$u_{mag}(\vec{r}, t) = \frac{1}{2\mu_o} B^2(\vec{r}, t) = \frac{1}{2\mu_o} \vec{B}(\vec{r}, t) \cdot \vec{B}(\vec{r}, t) = \frac{1}{2} \vec{B}(\vec{r}, t) \cdot \vec{H}(\vec{r}, t) \text{ (Joules/m}^3\text{)}$$

We can see that these are directly analogous to the electric field case:
 The energy associated with the electric field in any system is given by:

$$W_{elect}(t) = \int_{space} u_{elect}(\vec{r}, t) d\tau = \frac{1}{2} \int_{space} (\rho_{Tot}(\vec{r}, t) V(\vec{r}, t)) d\tau \quad \text{(Joules) or equivalently by:}$$

$$W_{elect}(t) = \int_{space} u_{elect}(\vec{r}, t) d\tau = \frac{1}{2} \epsilon_o \int_{space} E^2(\vec{r}, t) d\tau$$

$$= \frac{1}{2} \epsilon_o \int_{space} (\vec{E}(\vec{r}, t) \cdot \vec{E}(\vec{r}, t)) d\tau = \frac{1}{2} \int_{space} (\vec{E}(\vec{r}, t) \cdot \vec{D}(\vec{r}, t)) d\tau \quad \text{(Joules)}$$

The corresponding electric energy density is given by:

$$u_{elect}(\vec{r}, t) = \frac{1}{2} \rho_{Tot}(\vec{r}, t) V(\vec{r}, t) \quad \text{(Joules/m}^3\text{) or equivalently by:}$$

$$u_{elect}(\vec{r}, t) = \frac{1}{2} \epsilon_o E^2(\vec{r}, t) = \frac{1}{2} \epsilon_o \vec{E}(\vec{r}, t) \cdot \vec{E}(\vec{r}, t) = \frac{1}{2} \vec{E}(\vec{r}, t) \cdot \vec{D}(\vec{r}, t) \quad \text{(Joules/m}^3\text{)}$$

Electric and Magnetic Energies & Energy Densities in Macroscopic Matter – Linear Media:

In linear dielectric materials, ϵ_o (free space) \rightarrow ϵ (linear medium), with $\vec{D}(\vec{r}, t) = \epsilon \vec{E}(\vec{r}, t)$

In linear magnetic materials, μ_o (free space) \rightarrow μ (linear medium), with $\vec{H}(\vec{r}, t) = \vec{B}(\vec{r}, t) / \mu$

The electric and magnetic energy densities in the volume v (only) of the linear media are:

$$u_{elect}^{dielectric}(\vec{r}, t) = \frac{1}{2} \epsilon E^2(\vec{r}, t) = \frac{1}{2} \epsilon \vec{E}(\vec{r}, t) \cdot \vec{E}(\vec{r}, t) = \frac{1}{2} \vec{E}(\vec{r}, t) \cdot \vec{D}(\vec{r}, t) \quad \text{(Joules/m}^3\text{)}$$

$$u_{mag}^{magnetic}(\vec{r}, t) = \frac{1}{2\mu} B^2(\vec{r}, t) = \frac{1}{2\mu} \vec{B}(\vec{r}, t) \cdot \vec{B}(\vec{r}, t) = \frac{1}{2} \vec{B}(\vec{r}, t) \cdot \vec{H}(\vec{r}, t) \quad \text{(Joules/m}^3\text{)}$$

The corresponding electric and magnetic energies associated with the volume v (only) of the linear media are:

$$W_{elect}^{dielectric}(t) = \int_v u_{elect}^{dielectric}(\vec{r}, t) d\tau = \frac{1}{2} \epsilon \int_v E^2(\vec{r}, t) d\tau$$

$$= \frac{1}{2} \epsilon \int_v (\vec{E}(\vec{r}, t) \cdot \vec{E}(\vec{r}, t)) d\tau = \frac{1}{2} \int_v (\vec{E}(\vec{r}, t) \cdot \vec{D}(\vec{r}, t)) d\tau \quad \text{(Joules)}$$

$$W_{mag}^{magnetic}(t) = \int_v u_{mag}^{magnetic}(\vec{r}, t) d\tau = \frac{1}{2\mu} \int_v B^2(\vec{r}, t) d\tau$$

$$= \frac{1}{2\mu} \int_v (\vec{B}(\vec{r}, t) \cdot \vec{B}(\vec{r}, t)) d\tau = \frac{1}{2} \int_v (\vec{B}(\vec{r}, t) \cdot \vec{H}(\vec{r}, t)) d\tau \quad \text{(Joules)}$$

The total electric/magnetic energy densities and electric/magnetic energies (i.e. integrated over all space must (obviously) use ϵ_o and μ_o for these integrals in the region(s) outside of the volume v of the media.

Griffiths Example 7.13:

A long coaxial cable carries a steady free current I_{free} down the surface of the inner cylinder (of radius a) and then returns along the surface of the outer cylinder (of radius b), as shown in the figure below:

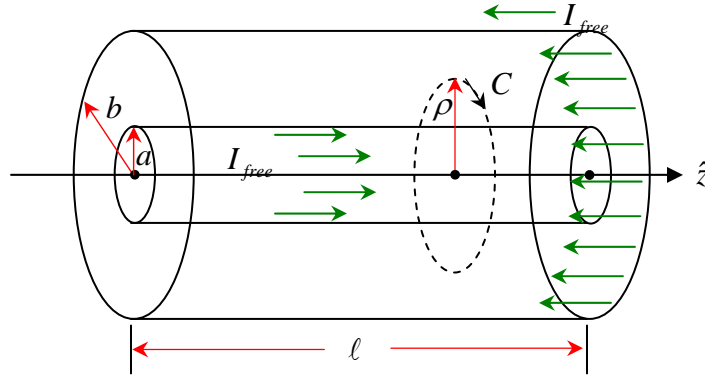

Determine the magnetic energy density stored in a section of this coaxial cable, e.g. associated with a length ℓ of this cable.

Use e.g. Ampere's circuital law $\oint_C \vec{B}(\vec{r}) \cdot d\vec{\ell} = \mu_o I_{Tot}^{enclosed}$ to determine B inside and outside the cable, take contour(s) as shown above.

For $\rho < a$, $I_{Tot}^{enclosed} = 0$	therefore $\vec{B}(\rho < a) = 0$.	$ \vec{B}(\rho) $
For $a \leq \rho < b$, $I_{Tot}^{enclosed} = I_{free}$	therefore $\vec{B}(a \leq \rho \leq b) = \frac{\mu_o}{2\pi\rho} I_{free} \hat{\phi}$.	
For $\rho > b$, $I_{Tot}^{enclosed} (net) = 0$	therefore $\vec{B}(\rho > b) = 0$.	

Since the magnetic field $\vec{B}(a \leq \rho \leq b) = \frac{\mu_o}{2\pi\rho} I_{free} \hat{\phi}$ is non-zero only in the region $a \leq \rho < b$, then the magnetic energy density will also be non-zero only in this same region:

$u_{mag}(\rho) = \frac{1}{2\mu_o} B^2(\rho) = \frac{1}{2\mu_o} \vec{B}(\rho) \cdot \vec{B}(\rho)$ $= \frac{1}{2\mu_o} \left[\frac{\mu_o}{2\pi\rho} \right]^2 I_{free}^2 = \frac{\mu_o}{8\pi^2 \rho^2} I_{free}^2$	$u_{mag}(\rho)$ (Joules/m ³)
--	---

The magnetic energy associated with a finite length ℓ of the coaxial cable is:

$$\begin{aligned}
 W_{mag} &= \frac{1}{2\mu_o} \int_V B^2(\vec{r}) d\tau = \frac{1}{2\mu_o} \int_{z=0}^{z=\ell} dz \int_{\rho=a}^{\rho=b} \rho d\rho \int_{\phi=0}^{\phi=2\pi} B^2(\vec{r}) d\phi \\
 &= \cancel{2} \cancel{\pi} \ell I_{free}^2 \frac{\mu_o}{8\pi^2} \int_{\rho=a}^{\rho=b} \frac{\cancel{\rho} d\rho}{\rho^2} = \frac{\mu_o}{4\pi} \ell I_{free}^2 \int_{\rho=a}^{\rho=b} \frac{d\rho}{\rho} = \frac{\mu_o}{4\pi} \ell I_{free}^2 \ln(b/a)
 \end{aligned}$$

Thus:
$$W_{mag} = \frac{\mu_o}{4\pi} \ell I_{free}^2 \ln\left(\frac{b}{a}\right) \quad (\text{Joules})$$

The magnetic energy per unit length associated with this coaxial cable is:

$$w_{mag} \equiv W_{mag} / \ell = \frac{\mu_o}{4\pi} I_{free}^2 \ln\left(\frac{b}{a}\right) \quad (\text{Joules/meter})$$

Note that the magnetic energy in this coaxial cable is also $W_{mag} = W_L = \frac{1}{2} L I_{free}^2$, thus we see that the inductance L associated with a finite length ℓ of this cable is:

$$W_{mag} = W_L = \frac{1}{2} L I_{free}^2 = \frac{\mu_o}{4\pi} \ell I_{free}^2 \ln\left(\frac{b}{a}\right) \Rightarrow L = \frac{\mu_o}{2\pi} \ell \ln\left(\frac{b}{a}\right) \quad (\text{Henrys}).$$

The inductance per unit length of this coaxial cable is therefore:

$$\mathcal{L} \equiv \frac{L}{\ell} = \frac{\mu_o}{2\pi} \ln\left(\frac{b}{a}\right) \quad (\text{Henrys/meter}).$$

Note that the inductance per unit length $\mathcal{L} \equiv L/\ell$ has the same SI units (Henrys/meter) as the magnetic permeability of free space μ_o .

Magnetic Forces:

Example: The Force on a Linear Magnetic Core Exerted by a Long Solenoid

Suppose we have a long solenoid of length ℓ and radius R (thus cross-sectional area $A_{\perp} = \pi R^2$) with N_{Tot} turns (thus $n = N_{Tot}/\ell$ turns per unit length) carrying a steady free current I . What happens when we insert a linear magnetic material (with constant magnetic permeability μ) having the same length and radius into the bore of the long solenoid? Is there a force acting on it, e.g. analogous to that associated with inserting a linear dielectric between the plates of a parallel-plate capacitor?

Cross-Sectional View of Long Solenoid:

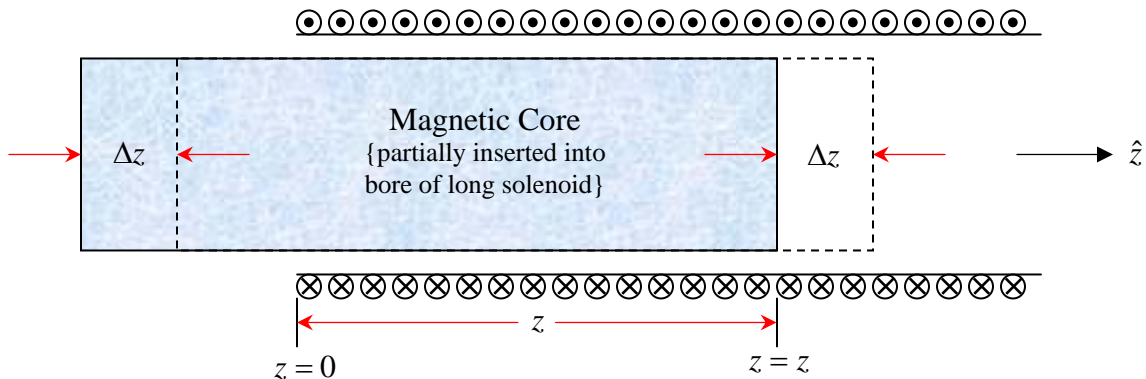

The infinitesimal difference in the magnetic energy associated with moving the magnetic core inward into the bore of the long solenoid an infinitesimal distance Δz (ignoring/neglecting any/all end effects) is given by:

$$\Delta W_{mag}(\Delta z) = W_{mag}(z + \Delta z) - W_{mag}(z) \approx \frac{1}{2}(\mu - \mu_o) \int_v H_{sol}^{in2}(\vec{r}) d\tau$$

Where (using Ampere's circuital law for the \vec{H} -field for the long solenoid): $\vec{H}_{sol}^{in}(\vec{r}) = nI_{free}\hat{z}$

The infinitesimal change in the volume due to the infinitesimal displacement Δz is $\Delta V = A_{\perp}\Delta z$.

$$\therefore \Delta W_{mag}(\Delta z) \approx \frac{1}{2}(\mu - \mu_o)n^2I_{free}^2A_{\perp}\Delta z$$

Then the net force acting on the magnetic core is:

$$\vec{F}_{mag}(\Delta z) = \left. \frac{\Delta W_{mag}(\Delta z)}{\Delta z} \right|_{I_{free}=\text{constant}} \hat{z} = \left. \frac{dW_{mag}(\Delta z)}{dz} \right|_{I_{free}=\text{constant}} \hat{z} \approx \frac{1}{2}(\mu - \mu_o)n^2I_{free}^2A_{\perp}\hat{z}$$

Thus, as long as $(\mu - \mu_o) > 0$ (i.e. paramagnetic materials) we see that the direction of the magnetic force acting on the magnetic core ($+\hat{z}$) is such that it wants to suck the magnetic core into the bore of the long solenoid, analogous to what we saw in the case of a linear dielectric partially inserted into the gap of a parallel-plate capacitor. Note however, for diamagnetic core, since $(\mu_{dia} - \mu_o) < 0$, a diamagnetic magnetic core is repelled from the bore of the long solenoid!

Electric and Magnetic Pressure:

We have seen for the electrostatics case, that the energy density $u_{elect}(\vec{r})$ (SI units of Joule/m³) also has the same units as that for pressure, $P(\vec{r})$ (Newtons/m²), and in fact the presence of an energy density $u(\vec{r})$ can/will exert a pressure $P(\vec{r})$ on material if present at the point \vec{r} .

If there are no linear dielectrics and/or linear magnetic materials present, then:

$$u_{elect}(\vec{r}, t) = P_{elect}(\vec{r}, t) = \frac{1}{2}\epsilon_o E^2(\vec{r}, t) = \frac{1}{2}\epsilon_o \vec{E}(\vec{r}, t) \cdot \vec{E}(\vec{r}, t) = \frac{1}{2}\vec{E}(\vec{r}, t) \cdot \vec{D}(\vec{r}, t) \quad (\text{J/m}^3 \text{ or N/m}^2)$$

$$u_{mag}(\vec{r}, t) = P_{mag}(\vec{r}, t) = \frac{1}{2\mu_o} B^2(\vec{r}, t) = \frac{1}{2\mu_o} \vec{B}(\vec{r}, t) \cdot \vec{B}(\vec{r}, t) = \frac{1}{2}\vec{B}(\vec{r}, t) \cdot \vec{H}(\vec{r}, t) \quad (\text{J/m}^3 \text{ or N/m}^2)$$

If there are linear dielectrics and/or linear magnetic materials present, then:

$$u_{elect}^{dielectric}(\vec{r}, t) = P_{elect}^{dielectric}(\vec{r}, t) = \frac{1}{2}\epsilon E^2(\vec{r}, t) = \frac{1}{2}\epsilon \vec{E}(\vec{r}, t) \cdot \vec{E}(\vec{r}, t) = \frac{1}{2}\vec{E}(\vec{r}, t) \cdot \vec{D}(\vec{r}, t) \quad (\text{J/m}^3 \text{ or N/m}^2)$$

$$u_{mag}^{magnetic}(\vec{r}, t) = P_{mag}^{magnetic}(\vec{r}, t) = \frac{1}{2\mu} B^2(\vec{r}, t) = \frac{1}{2\mu} \vec{B}(\vec{r}, t) \cdot \vec{B}(\vec{r}, t) = \frac{1}{2}\vec{B}(\vec{r}, t) \cdot \vec{H}(\vec{r}, t) \quad (\text{J/m}^3 \text{ or N/m}^2)$$

Example: The Magnetic Pressure Inside a Long Air-Core Solenoid

For simplicity, assume steady free current I_{free} flowing in windings of long air-core solenoid.

From Ampere's circuital law: $\vec{B}_{sol}^{in}(\vec{r}) = \mu_o n I_{free} \hat{z}$.

Note that:

$$u_{sol}^{inside}(\vec{r}) = P_{sol}^{inside}(\vec{r}) = \frac{1}{2\mu_o} B_{sol}^{in2}(\vec{r}) = \frac{1}{2} \mu_o n^2 I_{free}^2 = \text{constant} > 0 \quad (\text{i.e. is a positive quantity}).$$

Cross-Sectional View of Long Air-Core Solenoid:

$\vec{B}_{sol}^{in}(\vec{r}) \parallel \hat{z}$ points out of page:

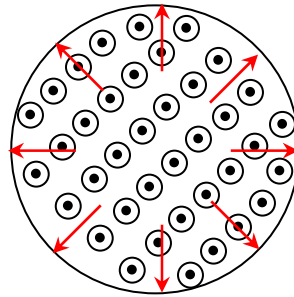

$$u_{mag}^{outside}(\vec{r}) = P_{mag}^{outside}(\vec{r}) = 0$$

$$u_{sol}^{in}(\vec{r}) = P_{sol}^{in}(\vec{r}) = \frac{1}{2\mu_o} B_{sol}^{in2}(\vec{r}) = \frac{1}{2} \mu_o n^2 I_{free}^2 = \text{constant} > 0$$

points radially outward

The magnetic pressure/magnetic energy density inside the solenoid pushes/exerts a radial-outward force on the solenoid!

The net magnetic force acting on the long air-core solenoid of radius R and length ℓ is:

$$\vec{F}_{sol}^{net} = P_{sol}^{inside}(\vec{r} = R) A_{sol} \hat{\rho} = \frac{1}{2} \mu_o n^2 I_{free}^2 \cdot 2\pi R \ell \hat{\rho} = \mu_o \pi n^2 I_{free}^2 R \ell \hat{\rho} \quad (\text{radially outward})$$

Example: The Magnetic Pressure Inside an Air-Core Toroid

Similar to the long, air-core solenoid, except $\vec{B}_{toroid}^{inside}(\vec{r}) = \frac{\mu_o N_{tot} I_{free}}{2\pi \rho} \hat{\phi}$ for $a \leq \rho \leq b$.

Then: $u_{toroid}^{inside}(\vec{r}) = P_{toroid}^{inside}(\vec{r}) = \frac{1}{2\mu_o} B_{toroid}^{in2}(\vec{r}) = \frac{\mu_o}{8\pi^2} \frac{N_{tot}^2 I_{free}^2}{\rho^2} \neq \text{constant} > 0$

@ inner radius:	$u_{toroid}^{inside}(\rho = a) = P_{toroid}^{inside}(\rho = a) = \frac{1}{2\mu_o} B_{toroid}^{in2}(\rho = a) = \frac{\mu_o}{8\pi^2} \frac{N_{tot}^2 I_{free}^2}{a^2}$	Force at inner radius is radially inward
@ outer radius:	$u_{toroid}^{inside}(\rho = b) = P_{toroid}^{inside}(\rho = b) = \frac{1}{2\mu_o} B_{toroid}^{in2}(\rho = b) = \frac{\mu_o}{8\pi^2} \frac{N_{tot}^2 I_{free}^2}{b^2}$	Force at outer radius is radially outward

Example: The Magnetic Pressure Associated with a Thin Cylindrical Current-Carrying Tube

A steady free sheet current $\vec{K}_{free}(\vec{r}) = K_o \hat{z}$ (Amperes/meter) flows down the surface of a long, very thin cylindrical conducting metal tube of radius a as shown in the figure below:

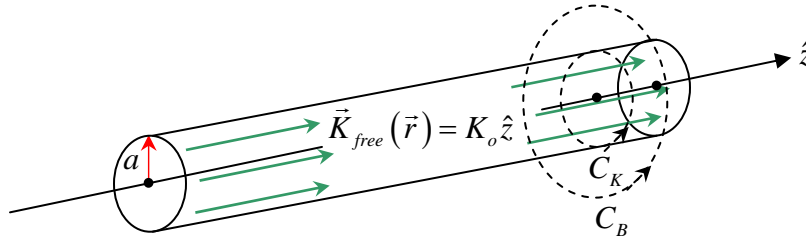

The (total) free current flowing down the surface of the conducting tube is:

$$I_{free} = \int_{C_K} \vec{K}_{free}(\vec{r}) \cdot d\vec{\ell}_{\perp} = \int_{C_K} K_o \hat{z} \cdot d\vec{\ell}_{\perp} = \int_{C_K} K_o \hat{z} \cdot a d\varphi \hat{z} = K_o a \int_0^{2\pi} d\varphi = 2\pi a K_o \equiv I_o$$

{ Since $d\vec{\ell}_{\perp} = a d\varphi \hat{z}$ using the arc length formula " $S = R\theta$ " }

Then using Ampere's law for \vec{B} : $\oint_{C_B} \vec{B}(\vec{r}) \cdot d\vec{\ell} = \mu_o I_{Tot}^{enclosed}$ we see that:

For $\rho < a: I_{Tot}^{enclosed} = 0 \Rightarrow \vec{B}(\rho < a) = 0$

$$\Rightarrow u_{mag}^{tube}(\rho < a) = P_{mag}^{tube}(\rho < a) = \frac{1}{2\mu_o} B_{tube}^2(\rho < a) = 0$$

For $\rho \geq a: I_{Tot}^{enclosed} = I_o \Rightarrow \vec{B}(\rho \geq a) = \frac{\mu_o I_o}{2\pi \rho} \hat{\phi}$

$$\Rightarrow u_{mag}^{tube}(\rho \geq a) = P_{mag}^{tube}(\rho \geq a) = \frac{1}{2\mu_o} B_{tube}^2(\rho \geq a) = \frac{\mu_o I_o^2}{8\pi^2 \rho^2}$$

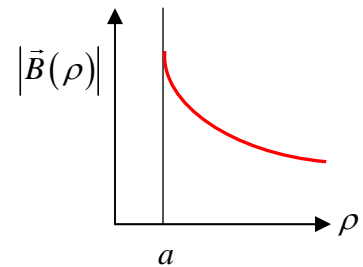

Thus {here}, since the magnetic field/magnetic energy density is only non-zero outside the long, thin conducting tube, the magnetic pressure creates a force on the tube which is radially inward.

The net force acting on the thin conducting tube is:

$$\vec{F}_{mag}^{tube}(\rho = a) = P_{mag}^{tube}(\rho = a) \cdot A_{tube} = \frac{\mu_o I_o^2}{8\pi^2 a^2} \cdot 2\pi a \ell = \frac{\mu_o I_o^2}{4\pi a} \ell$$

n.b. ℓ = length of the tube ($\ell \gg a$)

The net force per unit length acting on the thin conducting tube is:

$$\mathcal{F}(\rho = a) \equiv \frac{\vec{F}_{mag}^{tube}(\rho = a)}{\ell} = \frac{\mu_o I_o^2}{4\pi a}$$